



STEREO ENG MIXER

TABLE OF CONTENTS

ENGLISH

| | |
|---|----|
| GENERAL | 1 |
| FRONT PANEL CONTROLS AND INDICATORS (FIGURE 1) | 2 |
| INPUT PANEL CONNECTORS AND CONTROLS (FIGURE 2) | 4 |
| OUTPUT PANEL CONNECTORS AND CONTROLS (FIGURE 3) | 4 |
| INTERNAL SWITCHES AND CONTROLS (FIGURE 4) | 5 |
| INTERNAL SWITCHES AND CONTROLS (CONT.) | 6 |
| POWERING THE FP33 MIXER | 6 |
| BATTERY LIFE | 6 |
| MIXER SETUP | 7 |
| OPERATION | 7 |
| CONNECTING FP33 TRANSFORMER | |
| BALANCED OUTPUTS TO TELEPHONE LINES | 7 |
| USER ADJUSTMENTS | 8 |
| INTERNAL MODIFIABLE FUNCTIONS | 8 |
| SPECIFICATIONS | 10 |
| FURNISHED ACCESSORIES | 10 |
| STATEMENT OF CONFORMITY | 11 |
| INFORMATION TO USER | 11 |

GENERAL

The Shure FP33 is a three-input, two-output portable stereo mixer designed for professional electronic news gathering (ENG), electronic field production (EFP), and on-location film production. The FP33 mixer sets a new standard for portable mixer performance and features. An exceptionally low-noise design makes the FP33 ideal for use with digital transmission links or digital video and audio recording media, including DAT. Lightweight, compact, and rugged, the FP33 is designed to withstand the most demanding field production conditions.

All types of dynamic and condenser microphones may be used with the FP33. The mixer provides 48 V phantom, 12 V phantom, and 12 V T (A-B) power for operating condenser microphones. It will operate for at least 8 hours on two 9 V alkaline batteries. An external 12–30 Vdc power source, such as a Shure PS20 or PS20E ac adapter, may also be used.

Features

- Exceptionally quiet design, suitable for use with DAT and other digital formats
- Extended frequency response of 20 Hz–20 kHz
- Dynamic range greater than 100 dB
- Transformer balanced inputs and outputs for superior rejection of RFI and electromagnetic hum
- Three selectable mic/line inputs
- Two selectable mic/line outputs
- Wide range input gain controls handle hot signal levels without attenuators
- 48 V phantom, 12 V phantom, and 12 V T (A-B) microphone power
- Pop-up pan pots
- Link switch gangs inputs 2 and 3 to control a stereo microphone
- Switchable low-cut filters on each input
- Bi-color LED signal presence and peak indicator for each input
- Professional VU meters with selectable timed or toggled backlighting
- Dual clutched Master gain control for simultaneous or separate adjustment of output levels
- Precision, conductive plastic, sealed rotary input potentiometers
- Bi-color LED limiter and peak indicator for each output
- Two linkable output peak limiters with adjustable thresholds and release times
- Slate microphone and slate tone with selectable functions
- Isolated two-way talk-back using Monitor In and modified Slate Mic/Tape Out jack
- High tolerance 3.5 mm jacks for stereo Tape Out and Monitor In
- 1 kHz tone oscillator
- Mix bus jack and cable to link FP33 or FP32A mixers
- Headphone monitor mode switch to select L, L+R (Mono), R, or Stereo
- Internal headphone level adjustments to balance post-master audio levels and Monitor In levels at the headphone output
- Selectable M/S decoding circuit for headphone monitor.
- Mixer/Monitor In switch (locking and momentary)
- Internal Monitor defeat switch for split-feed headphone operation
- Headphone volume control
- 1/4 in. and 3.5 mm jacks for stereo headphone outputs.
- Customized operation via internal DIP switches, trim pots, slide switches, and optional jumpers
- Regulated voltage rails (± 15 Vdc) provide exceptional headroom
- Bi-color power On/Off LED
- Battery check switch and low battery warning LED
- Non-polarized external power jack
- External power operating range of 12 to 30 Vdc
- Soft-touch, color coded control knobs with raised position indicators
- Metal XLR input and output connectors
- Rugged, plated metal chassis
- Operates for 8 hours on two 9 V alkaline batteries
- Includes carrying case, shoulder strap, and mix bus cable
- Designed and manufactured in U.S.A.

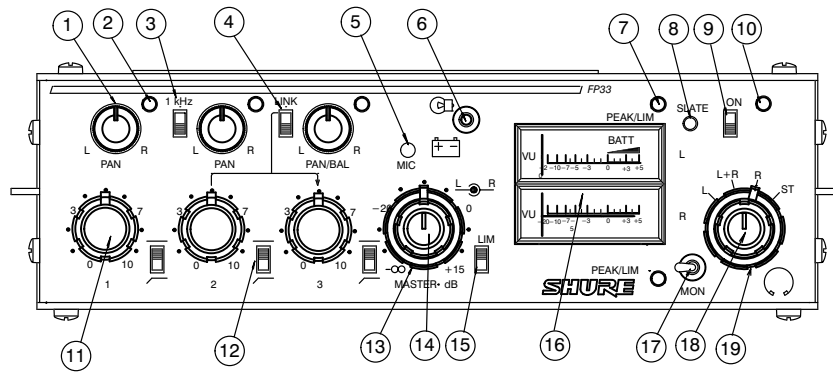

Figure 1

FRONT PANEL CONTROLS AND INDICATORS (Figure 1)

1. **Pan Control:** Adjusts the amount of input signal sent to the Left and Right outputs. Each Pan knob has a center detent position. To avoid accidental movement of the knob once it has been set, it may be pushed in flush with the front panel.
Note: Pan Control 3 becomes a Left/Right Balance Control when the LINK switch is activated (see the LINK switch description for details).
2. **Input Level Bi-Color LED:** Glows green to indicate the presence and relative level of an input signal. Also glows red if the input signal reaches 6 dB below the clipping (distortion) level. To program this LED so that it functions only as a clipping level indicator, open the battery compartment and move DIP Switch 10 to the Off position.
3. **1 kHz Tone Oscillator Switch:** Use the 1 kHz tone to send a reference signal to any device connected to an FP33 output. The 1 kHz tone mutes all inputs. The tone level can be adjusted with the Master control.
4. **Link Switch:** In the LINK position (up), this switch links the gain controls of Inputs 2 and 3 so they act as a stereo pair. Input 2 is Left and Input 3 is Right. The Input 3 Gain knob adjusts the level of the stereo pair. The Input 3 Pan knob adjusts the Left/Right balance.
Note: Channel 2 Gain and Pan are disabled when the LINK switch is activated. The low-cut filters for Input 2 and Input 3 are not linked.
5. **Slate Microphone:** The built-in condenser microphone is activated when the Slate button is pressed. See the Slate Button section for more information.
Note: To disable both the Slate microphone and the Slate tone, set internal DIP Switches 5, 6, and 7 to Off. The Slate microphone may also be modified to act as a talk-back microphone for communications. Refer to the Internal Modifiable Functions section for details.
6. **Meter Lamp/Battery Check Switch:** The Meter Lamp function is activated by momentarily pushing this switch upward. This function can be internally preset for timed or toggled deactivation. See the table in the Internal Switches and Controls section for details. The Battery Check function is activated by momentarily pushing this switch downward. The status of the two 9 V batteries is indicated on the VU meter. When the mixer is using an external dc supply and no batter-

- ies, the Battery Check indicates the status of the external operating voltage. When the mixer is using 9 V batteries *and* an external dc supply, the Battery Check indicates the status of the higher voltage source. A low battery condition also is indicated when the Power On LED changes to red and flashes at a slower rate. For instructions on modifying the FP33 to allow only internal batteries or external power to be monitored at the VU meter, see Internal Modifiable Functions.
Note: The audio signal is not interrupted when the Battery Check switch is activated.
7. **Output Peak/Limiter Bi-Color LED:** Glows red for the individual Left and Right Channels when the output signal reaches a factory preset peak level of +17 dBm. This peak level is user-adjustable from 0 dBm to +17 dBm. (See the Peak LED Adjustment instructions.) If the Limiter is switched on, each LED glows green to indicate Limiter operation. The LED will still glow red if the preset peak level is reached before the Limiter activation point is reached.
8. **Slate Button:** Activates a 400 Hz Slate Tone for one second and also activates the Slate Microphone. The Slate Microphone remains on while the button is depressed. The Slate signal (Tone and Mic) appears at the Left and Right outputs to identify the beginning of a take. If desired, the Slate features can be modified as follows: disable the Slate Tone; insert the Slate signal pre-Master control; or insert the Slate signal post-Master control. See the Internal DIP Switches table for instructions.
Note: To disable both the Slate microphone *and* the Slate tone, set internal DIP Switches 5, 6, and 7 to Off.
9. **Power On/Off Switch:** Turns the mixer on and off. The mixer is on when this switch is in the “up” position.
10. **Power On LED:** Monitors the higher of the internal or external voltage sources. Flashes green to indicate power is on and voltage is greater than 12 Vdc. Flashes red and slower to indicate low power (12 Vdc or less).
When this LED monitors the internal battery level, it glows red typically when 30 minutes of battery power remain. Refer to the Internal Battery Life section. For instructions on modifying the FP33 to allow only internal batteries or external power to be monitored at

the VU meter, refer to the Internal Modifiable Functions section.

11. **Input Gain Control:** Adjusts the gain level of each input channel. Rotating the knob counterclockwise reduces the gain and raises the input clipping point. Use a low control setting to handle “hotter” input signals without distortion. With the FP33 input circuit, microphones with a “hot” output may be used without an inline pad (attenuator). For best performance, adjust each Input Gain control so the associated Input Level LED illuminates red only on the loudest signal peaks.
12. **Input Low-Cut Filter Switch:** Provides low-frequency roll-off to reduce wind noise and rumble. When using the filter, the frequency response is down 6 dB at 150 Hz. The roll-off slope is 6 dB per octave.
13. **Master Gain—Right Channel Output:** The outer ring controls the Right channel output gain. The dual-clutched control lets the Right and Left outputs be adjusted individually. Set it to “0 dB” for unity gain.
14. **Master Gain—Left Channel Output:** The inner knob controls the Left channel output gain. The dual-clutched control lets the Right and Left outputs be adjusted individually. Set it to “0 dB” for unity gain.

Note: The 1 kHz tone oscillator level is set by the Master Level controls. To calibrate other devices, adjust the Master Level controls for a 0 VU response.

15. **Output Peak Limiter Switch:** Activates two fast-acting, peak-responding limiters, one for each output channel. Limiters help prevent overload distortion from unexpected loud input signals. The limiter activation is indicated by the Output Peak/Limiter LEDs, which illuminate green.

The limiters may be changed to: operate independently; be linked as a stereo pair; activate at thresholds from 0 dBm to +15 dBm; and have release time constants of 0.1 second or 1 second. See the Internal

DIP Switches and Limiter Threshold Adjustment for instructions.

16. **Left/Right Channel Output Level Meters:** 0 VU is preset at a +4 dBm output level. This may be recalibrated for each meter by an internal trim potentiometer. See the VU Meter Adjustment paragraph for instructions.

Note: Mechanical meters are used because LCD meters do not operate properly in cold weather; fluorescent meters drain batteries too quickly; and LED meters are difficult to see in sunlight.
17. **Monitor Input Switch:** In the center position, this switch sends the post-master audio to the headphone output. In the left (locking) or right (momentary) position, it sends the audio signal from the Monitor In jack to the headphone output.
18. **Headphone Gain Control (Inner Knob):** Adjusts the headphone volume level.

WARNING: The headphone circuit is capable of producing high volume levels that can damage the user’s hearing. Make sure the headphone volume setting is low (fully CCW) before putting on the headphones.

19. **Headphone Monitor Mode Switch (Outer Ring):** The user can monitor the FP33 output as: Stereo; Right channel only; Mono (Left + Right); or Left channel only.

Note: This switch also affects the Monitor In signal. When using a stereo MS microphone, such as the Shure VP88, the user may wish to pass the mic signal through the FP33 as separate Mid and Side signals, yet hear decoded stereo in the headphones. Using the Headphone MS Matrix, the user can monitor the FP33 output as: Discrete (Mid and Side); Side only, Stereo (decoded MS), or Mono (Mid only). Refer to the Internal DIP Switch table for instructions on activating the Headphone MS Matrix.

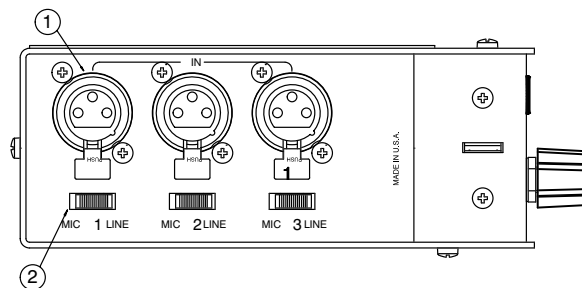

Figure 2

INPUT PANEL CONNECTORS AND CONTROLS (Figure 2)

1. **Channel Inputs:** The three female XLR inputs are transformer balanced for superior rejection of hum, RFI, and other interference. Each input can provide 48 V or 12 V phantom power (for condenser microphones); 12 V T (A-B) power (for condenser microphones); or no power (for dynamic microphones). See the Internal Switches and Controls section.
2. **Mic/Line Level Input Switch:** Selects Microphone or Line to match the incoming signal level. The Mic signal level is typically 0.1–3 mV, and the Line signal level is typically 0.1–3.0 V. In the Line level position, phantom and T power are disconnected from the input.

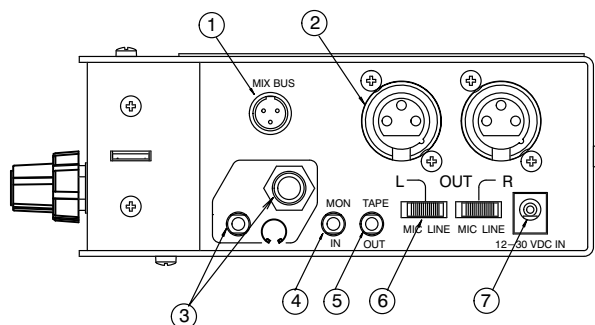

Figure 3

OUTPUT PANEL CONNECTORS AND CONTROLS (Figure 3)

1. **Mix Bus Jack:** Allows an FP33 to be connected to an additional FP33 or FP32A mixer. A mix bus cable is supplied with every FP33. The Mix Bus connection is "two-way" and pre-Master. When two mixers are connected via the Mix Bus, all six inputs appear at both mixers' outputs. The Master Gain control of either mixer can be adjusted without affecting the output of the other. This provides the equivalent of a six-input stereo mixer with two separate Master output sections.
Note: The output level of both mixers will drop by 6 dB when they are connected via the Mix Bus. Increase the Master Gain to compensate for this.
2. **Main Output:** The two male XLR outputs are transformer balanced and may be switched to Mic or Line Level. The Line Level output can be modified to a true 600 Ω. See the Internal Modifiable Functions section.
3. **Headphones Outputs:** A stereo 1/4 in. phone jack and a stereo 3.5 mm mini-phone jack may be used separately, simultaneously, or as auxiliary feeds to other equipment.
4. **Monitor In Jack:** Designed to accept stereo line-level signals. This 3.5 mm jack provides a "tape return" input or a communications channel input. This signal appears only in the FP33 headphone circuit. Activating the front panel Monitor In switch routes the Monitor In signal to the headphones. Program audio is *not heard* in the headphones when this switch is on.
Note: A "split-feed" (FP33 audio in one ear and Monitor In audio in the other) can be accomplished via internal DIP Switches 4 and 5. Also, an internal modification will allow attenuated FP33 audio to be heard in the headphones even when the Monitor In switch is activated. Refer to the Internal Modifiable Functions section.
5. **Tape Output Jack:** A stereo 3.5 mm mini-phone jack (auxiliary level) to feed a cassette recorder, DAT machine, or semi-pro video recorder. This output can be modified to provide a mono (L+R) signal; provide an unbalanced line level or mic level output; provide an isolated output containing only the Slate mic and Slate tone. Refer to the Internal Modifiable Functions section.
6. **Mic/Line Level Output Switch:** Selects Mic or Line Level to match the input level of the device connected to the FP33 output. The Mic signal level is typically 0.1–3 mV; the Line signal level is typically 0.1–3 V.
7. **12–30 Vdc In Jack (External Power):** This accepts a non-polarized coaxial plug from a 12 to 30 Vdc external power supply. The external supply must have a negative ground or a floating ground. A Shure PS20 or PS20E ac adapter, an automotive battery, or a rechargeable belt pack are all suitable power supplies.

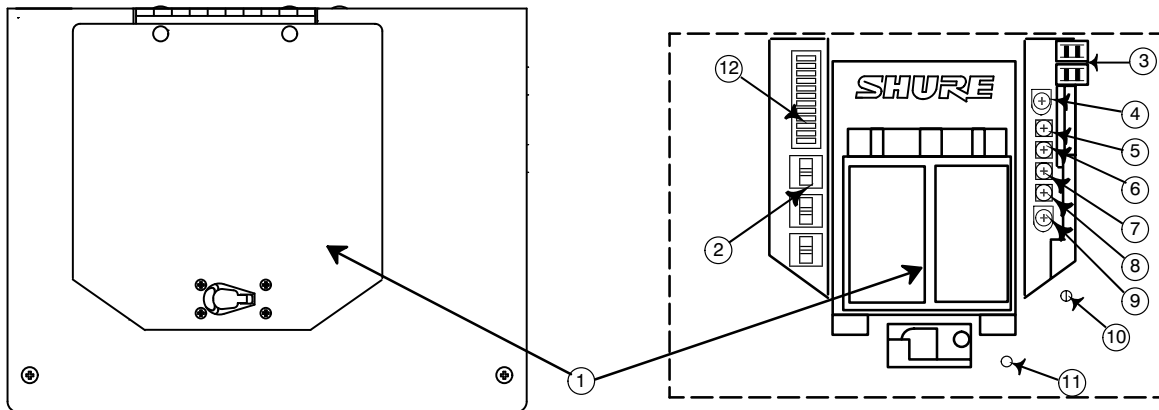

Figure 4

INTERNAL SWITCHES AND CONTROLS (NO TAG)

- Battery Compartment:** Holds two 9 V alkaline batteries. Two fresh batteries will power the unit for about eight hours under normal conditions.
- Microphone Power Selection Switch:** Position this slide switch to match the type of input power desired:
Top Position 12V T (A-B): Refer to Figure 5. Used with certain Sennheiser and Schoeps microphones.

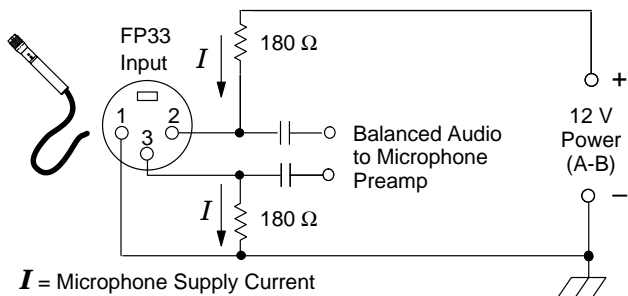

Figure 5

Middle Position (Dynamic): No dc power on pins 1, 2, or 3. Used with dynamic microphones or condenser microphones that have internal batteries.

Bottom Position (Phantom): Refer to Figure 6. Internal DIP switch 11 selects 12 volts or 48 volts. 48 V phantom power drains the batteries faster than 12 V phantom power. Used with all condenser microphones that do not require T power.

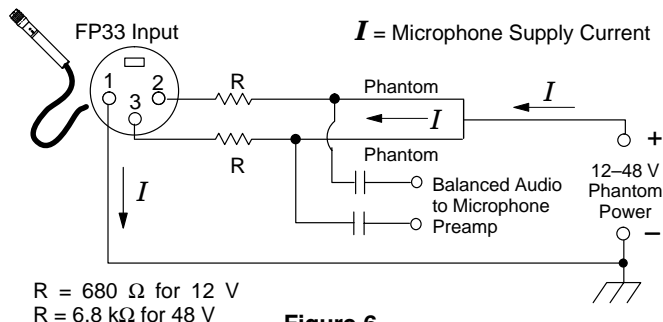

Figure 6

Caution: Balanced dynamic microphones will not be damaged by phantom power but may be damaged by T power.

- Fuse and Spare Fuse:** Designed to protect the FP33 from damage that may result from using a common external dc power supply with other electronic devices.
Caution: Damage may result when using a common external dc power supply with other electronic devices that are “positive ground.” Separate power supplies are recommended.
- Level R Potentiometer:** Attenuates the level of the FP33 right channel program audio that is fed to the headphone/monitor circuit. This does not affect the Monitor In levels at the headphone output.
- Peak LED R Potentiometer:** Adjusts the Right Peak LED to light at a preset output level. The factory setting is +17 dBm. The user adjustment range is 0 dBm to +17 dBm. See the Peak LED Adjustment paragraph.
- Peak LED L Potentiometer:** Adjusts the Left Peak LED to light at a preset output level. The factory setting is +17 dBm. The user adjustment range is 0 dBm to +17 dBm. See the Peak LED Adjustment paragraph.
- Lim Adj R Potentiometer:** Adjusts the Right limiter to operate at a preset output level. The factory setting is +15 dBm. The user adjustment range is 0 to +15 dBm. See the Limiter Threshold Adjustment paragraph.
- Lim Adj L Potentiometer:** Adjusts the Left limiter to operate at a preset output level. The factory setting is +15 dBm. The user adjustment range is 0 to +15 dBm. See the Limiter Threshold Adjustment paragraph.
- Level L Potentiometer:** Attenuates the level of the FP33 left channel program audio that is fed to the headphone/monitor circuit. This does not affect the Monitor In levels at the headphone output.
- Meter Adj R Potentiometer:** Adjusts the Right meter to indicate 0 VU at a preset output level. The factory setting is +4 dBm. The user adjustment range is 0 to +16 dBm. Refer to the VU Meter Adjustment paragraph.
- Meter Adj L Potentiometer:** Adjusts the Left meter to indicate 0 VU at a preset output level. The factory setting is +4 dBm. The user adjustment range is 0 dBm to +16 dBm. See the VU Meter Adjustment paragraph.
- Internal DIP Switches:** 12 internal DIP switches allow the user to customize operation. The function of each DIP switch is listed in the table on the following page.

INTERNAL SWITCHES AND CONTROLS (Cont.)

Note: Bold type indicates the Factory setting.

| DIP SWITCH | POSITION | FUNCTION |
|-----------------------------|--------------|--|
| 1 LIM LINK | ON | Left and Right limiters act in tandem. If limiter thresholds are set differently, limiter action is determined by the lower threshold setting. |
| | OFF | Left and Right limiters act independently. |
| 2 LIM RELEASE R | SHORT | Right limiter release time constant is 0.1 second. Use for speech. |
| | LONG | Right limiter release time constant is 1 second. Use for music. |
| 3 LIM RELEASE L | SHORT | Left limiter release time constant is 0.1 second. Use for speech. |
| | LONG | Left limiter release time constant is 1 second. Use for music. |
| 4 MON DEFEAT R | OFF | When front panel Monitor switch is activated, Monitor In signal is heard in Right headphone. |
| | ON | When front panel Monitor switch is activated, Monitor In signal is <u>not</u> heard in Right headphone. Mixer audio remains in Right headphone. |
| 5 MON DEFEAT L | OFF | When front panel Monitor switch is activated, Monitor In signal is heard in Left headphone. |
| | ON | When front panel Monitor switch is activated, Monitor In signal is <u>not</u> heard in Left headphone. Mixer audio remains in Left headphone. |
| 6 PRE-MAST SLATE | ON | Inserts slate tone and slate microphone into circuit <u>before</u> the Master gain control (pre-master). Slate level is controlled by Master. |
| | OFF | Removes slate tone/slate microphone from pre-master circuit. |
| 7 POST-MAST SLATE | ON | Inserts slate tone and slate microphone into FP33 circuit <u>after</u> the Master gain control (post-master). Slate level not is controlled by Master. |
| | OFF | Removes slate tone and slate microphone from FP33 post-master circuit. |
| 8 SLATE TONE | ON | Slate tone (400 Hz) sounds for one second when front panel slate button is pushed. Slate microphone also activates. |
| | OFF | Slate tone does not sound when slate button is pushed. Slate microphone does activate. |
| 9 METER LAMP | TOGGLED | Lamp turns on/off when front panel lamp switch is toggled. Automatic timed turnoff of lamp will <u>not</u> occur. |
| | TIMED | Lamp turns on/off when front panel lamp switch is activated. If not manually switched off, lamp will automatically turn off after 10 seconds to conserve battery life. |
| 10 PRESENCE LEDs | ON | Input LEDs illuminate green to indicate signal presence and relative level. |
| | OFF | Input LEDs do <u>not</u> illuminate green. Input LEDs will still illuminate red to indicate 6 dB before clipping. |
| 11 12 V OR 48 V PHANTOM | 12V | Provides 12 Vdc phantom power if selected for channel input. |
| | 48V | Provides 48 Vdc phantom power if selected for channel input. |
| 12 MS MATRIX FOR HEADPHONES | ON | Inserts MS decoding matrix into headphone circuit. User can monitor in stereo while allowing separate Mic and Side signals to pass through the FP33. |
| | OFF | Removes MS decoding matrix from headphone circuit. |

POWERING THE FP33 MIXER

The FP33 can be powered by a 12–30 Vdc external power supply while preserving the life of the internal batteries.

| External Power Supplied | Internal Batteries |
|-------------------------|---|
| 11.4 Vdc to 30 Vdc | OFF (200 μ A current at 18 V) |
| <11.4 Vdc | ON (Full power for the FP33 is supplied by the higher voltage source) |

BATTERY LIFE

The FP33 is designed for low current consumption. Under typical conditions (+4 dBm into 600 Ω in continuous use and no phantom-powered microphones, meter illumination, or headphones in use), and with two fresh 9 volt alkaline batteries, the FP33 will operate for about eight hours before the Power LED flashes. At this point, about 30 minutes of battery life remain. If more mixer features are used, battery life will decrease accordingly (see table).

| Mixer Operation | Battery Current (mA) | Battery Life (hours)* |
|---|----------------------|-----------------------|
| (A) Idle, no signal | 41 | 9 |
| (B) As in (A) with +4 dBm continuous output | 46 | 7.8 |
| (C) As in (B) with three Shure SM81 microphones at 12 V phantom power | 50 | 7.5 |
| (D) As in (B) with three Shure SM81 microphones at 48 V phantom power | 57 | 6.0 |
| (E) As in (B) with 63 Ω headphones driven moderately loud (Sony MDRV6) | 50 | 6.9 |
| (F) As in (B) with meter illumination continuously on | 63 | 5.5 |

*Until Power LED begins to flash, and allowing 30 minutes to replace batteries.

Note: Momentary use of headphones or meter illumination will not appreciably affect battery life.

MIXER SETUP

Prepare the FP33 stereo mixer for operation as follows:

1. For internal battery operation, lift the latch on the top panel and open the battery compartment. Install two 9 V alkaline batteries, making sure the polarity (+/-) is correct. Select the proper microphone powering for each input via the slide switches. Close the compartment door and secure the latch. For external power operation, plug a 12 to 30 Vdc source into the External Power jack on the right side panel of the FP33.
2. Connect the microphone, wireless receiver, or other audio source to the desired Input Channel connector on the left side panel.

Note: When using a stereo microphone, such as the Shure VP88, connect it to Channels 2 and 3. Use the front panel LINK switch to make Inputs 2 and 3 a stereo pair. In the LINK mode: Channel 2 = Left or Mid; Channel 3 = Right or Side.

3. Position each Mic/Line Input switch based on the level of the incoming source.
4. Connect the camcorder, DAT machine, wireless transmitter, or other equipment to the Left and Right Output XLR connectors on the right side panel of the FP33.
5. Position each Mic/Line Output switch based on the input level requirements of the equipment connected to the FP33 outputs.
6. If a "tape return" or Monitor In feed into the FP33 is required, connect a 3.5 mm stereo male plug into the Mon In connector on the right side panel. The signal on this plug typically comes from the audio output of whatever device is being fed by the FP33. See NO TAG.

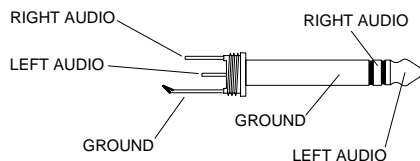

Figure 7

7. If an unbalanced output feed is desired, connect a 3.5 mm stereo male plug into the Tape Out connector on the right side panel. This would typically feed a cassette recorder or a DAT machine. Refer to NO TAG.
8. Plug headphones into the stereo 1/4 in. phone or 3.5 mm mini-phone jacks on the right side panel.

Note: The two headphone output connectors may be used separately, simultaneously, or as auxiliary feeds to other equipment.
9. To interconnect two mixers, plug the supplied Mix Bus cable into the Mix Bus connectors of both mixers.

Note: When two FP33 or FP32A mixers are interconnected via the Mix Bus, the Master Gain on either mixer can be adjusted without affecting the other mixer's output level. This provides the equivalent of a six-input stereo mixer with two separate Master output sections.
10. Set the Master Gain, Headphone Volume, and all Input Gains fully counterclockwise (off).

OPERATION

To operate the FP33 stereo mixer, proceed as follows:

1. Apply power to the mixer by sliding the On/Off switch to the On position. The green Power On LED will flash at a constant rate to indicate that the mixer is turned on.
2. Check the mixer power status by moving the front panel Battery Check switch downward toward the battery icon. The needle on the top VU meter will swing to the sloped red BATT indication. If the needle falls below the red BATT indication, the unit is not receiving adequate power from the internal 9 V batteries or the external dc supply.
3. Move the front panel MON toggle switch to the center position to route FP33 audio to the headphones. Setting this switch to the left or right routes the Monitor In audio to the headphones. The right position is momentary, for quickly checking the Monitor In audio.
4. Slide the LIM switch to the desired position: Up to turn the output limiters on, Down to turn them off. Keep the limiters on to protect against output overload.
5. Position the Low-Cut Filter switches for each Input: Up for low-cut off, Down for low-cut on.
6. For an initial gain setting, rotate the Master Gain knob to "0 dB" (2 o'clock). This provides unity gain for the output stages. **Note:** the Master Gain can be adjusted during mixer operation as input levels vary.
7. Activate the 1 kHz tone oscillator by sliding the switch to the On (up) position. Use the tone to set the input level control of the device following the FP33. Once the input level of the following device is set, slide the switch to the Off (down) position to turn off the tone. **Note:** The tone oscillator of the FP33 is not used to set the controls of the FP33. Those are set according to the input signals coming into the FP33.
8. Rotate the Headphone Monitor Mode knob to the ST (Stereo) position.
9. Put on headphones and carefully adjust the headphone volume control.

WARNING: The headphone circuit is capable of producing loud levels that can damage the user's hearing. Be sure the headphone volume setting is low (fully CCW) before putting on the headphones.

10. Adjust the Input Gain and Pan controls based on the incoming signal levels. The Input LEDs should flicker red only on the loudest input peaks. After these settings have been made, the Pan knobs can be pressed flush to the front panel to avoid accidental movement.
11. Observe the output on the VU meters and adjust the Master Gain to obtain the desired levels. Try to keep the average levels around "0 VU."

Note: To illuminate the VU meters, move the front panel toggle switch up toward the light bulb symbol.
12. Press the Slate button to insert a momentary 400 Hz Slate tone into the FP33 output for "take" identification purposes. The FP33 mixer is now ready for use.

Note: If desired, vocally identify the "take" via the Slate Mic while pressing the Slate button.

CONNECTING FP33 TRANSFORMER BALANCED OUTPUTS TO TELEPHONE LINES

In the Line position, the Left and Right XLR outputs can be used to drive dc-biased, "dialed up" telephone lines,

although there may be a slight increase in distortion. Use of the limiter circuit is strongly advised, with the FP33 limiter threshold set to +4 dBm. Modification of the FP33 output impedance to 600 Ω is recommended for proper fidelity. (See the Internal Modifiable Functions section for instructions.) When connecting the FP33 to a telephone line in the United States, use of an FCC-Registered interface adapter between the mixer and the telephone line is mandatory. Outside the U.S., consult the local telecommunications authority.

USER ADJUSTMENTS

VU Meter Adjustment

To set the VU Meters to a value other than the factory setting (0 VU = +4 dBm), proceed as follows:

1. Connect a 600 Ω load across the Left XLR output set for Line.
2. Connect an ac voltmeter (such as the HP 400GL) in parallel with the load.
3. Slide the 1 kHz tone oscillator switch to the On (up) position.
4. Adjust the 1 kHz Tone Oscillator level with the Left (inside) Master gain control until the ac voltmeter reading is at the level desired.
5. Open the battery compartment door and adjust the Left VU Level trim pot with a screwdriver until the Left VU Meter reads 0.
6. Repeat the above procedure for the Right Output and the Right VU Meter.

Limiter Threshold Adjustment

To adjust the Limiter threshold to a value other than the factory setting (+15 dBm), proceed as follows:

1. Connect a 600 Ω load and an ac voltmeter across the Left Line output as described in steps 1 and 2 of the VU Meter Adjustment procedure.
2. Open the battery compartment and move DIP switch 1 to the Off position (refer to the chart on the inside of the door).
3. Slide the 1 kHz tone oscillator switch to the On (up) position.
4. Slide the Limiter switch to the Off (down) position.
5. Adjust the Left Master gain control until the ac voltmeter reading is 2 dB above the desired output level.
6. Slide the Limiter switch to the On (LIM) position.
7. Open the battery compartment and adjust the Lim Adj L trim pot until the level drops to the desired reading.
8. Repeat the above procedure for the Right output, using the Lim Adj R trim pot.

Peak LED Adjustment

To adjust the Peak LED threshold to a value other than the factory setting (+17 dBm), proceed as follows:

1. Connect a 600 Ω load and an ac voltmeter across the Left Line output as described in steps 1 and 2 of the VU Meter Adjustment procedure.
2. Slide the 1 kHz tone oscillator switch to the On (up) position.
3. Slide the Limiter switch to the Off (down) position.
4. Adjust the Left Master gain control until the ac voltmeter reading is at the desired peak output level.

5. Open the battery compartment and turn the Peak LED L trim pot completely clockwise.
6. Slowly adjust the trim pot counterclockwise until the left Peak/Lim LED first illuminates red.
7. Repeat the above procedure for the right Peak/Lim LED, using the Peak LED R trim pot.

Headphone Level Adjustments

To adjust the program level to match the audio signal levels from a monitored source, proceed as follows:

1. Open the battery compartment and adjust the Headphone Level L and Headphone Level R full counterclockwise.
2. Connect the device to be monitored via the 3.5 mm Monitor In jack.
3. Move the Monitor Input Switch on the front panel to the locking position (left).
4. Adjust the monitor input level, using the headphone gain control on the front panel.
5. Move the Monitor Input switch on the front panel to the post-master audio position (center).
6. Adjust the post-master audio to a comparable level, using the Headphone Level L and Headphone Level R potentiometers.

INTERNAL MODIFIABLE FUNCTIONS

Selected internal functions of the FP33 can be modified by the user to fit special applications. Procedures for performing these modifications are listed below.

CAUTION: Due to the complex construction and extensive use of surface-mount components, modifications to the FP33 must be performed by a qualified service technician. Contact the Shure Service Department or your authorized Shure Service Center for further information on these modifications.

Disassembly

1. Remove the six screws that secure the cover.
2. Slowly slide the cover backwards and unplug ribbon cable P109.
3. Remove the three screws (marked with arrows) that secure the upper PC board.
4. Remove the upper PC board.
5. Perform the appropriate modification procedure.
6. Reassemble the unit by doing Steps 1–4 in reverse.

Changing the Line Level Output Impedance to 600 Ω

1. Locate R674 and R668 on the bottom PC board and remove them.
2. Locate X503 and X505 on the bottom PC board and solder a 470 Ω , 1/2W resistor through the holes at X503.
3. Solder a 470 Ω , 1/2W resistor through the holes at X505.

Changing the Tape Out Jack from Stereo (tip = L; ring = R) to Mono (tip = L+R; ring = L+R)

1. Locate X504 on the top side of the lower PC board, by the Tape Out jack.
2. Solder a jumper through the holes at X504.

Decreasing Tape Out Level to Mic Level

1. Locate R1112 and X511 (the top side of the bottom PC board, by the L Out XLR connector).

2. Locate R1114 and X510 (the bottom side of the bottom PC board, by the Tape Out jack).
3. Remove R1112 and R1114.
4. Solder a jumper through the holes at X511.
5. Solder a jumper through the holes at X510.

Increasing the Tape Out Level by +10 dB

1. Locate R669 and R672 on the bottom PC board.
2. Remove these two resistors.
3. The Tape Out impedance is now 6 kΩ.

Changing the Slate Mic and the Slate Tone to Feed Only the Tape Out Jack

This modification provides an isolated, unbalanced output for talk-back. For example, the user could talk to a boom operator through the Slate mic. The Monitor In function could be used to hear the boom operator’s response.

1. Locate and remove R663, R669, R670, R672, R673, and R765 from the bottom PC board.
2. Solder a jumper through the holes at X504 (behind the Tape Out jack).
3. Solder one end of an insulated jumper into the hole at X600 (about 40 mm [1.5 in.] behind the Tape Out jack).
4. Solder the other end of this jumper to the jumper at X504.
5. Set the Pre-Mast Slate DIP switch (#6) to On.
6. Set the Post-Mast Slate DIP switch (#7) to Off.
7. The nominal Tape Out level is now –10 dBV (aux level). The Modified Tape Out contains *only* the Slate tone and Slate microphone. The Slate tone and Slate microphone are removed from the main outputs.

Providing Mixer Audio in the Headphones when the Monitor Switch is Activated

This modification allows the user to listen to the monitor input signal and attenuated mixer audio simultaneously.

1. Locate X501 and X502 on the bottom PC board.
2. Determine the amount of attenuation desired for mixer audio, using the following table.

| Mixer Audio Attenuation | Required Resistor Impedance |
|-------------------------|-----------------------------|
| Less than 10 dB | Less than 150 kΩ |
| 10 dB | 150 kΩ |
| 15 dB | 300 kΩ |
| Greater than 15 dB | Greater than 300 kΩ |

3. Solder a 1/8W or 1/4W resistor through the holes at X501.
4. Solder a 1/8W or 1/4W resistor through the holes at X502.
5. Activate the Monitor In switch. FP33 audio will be attenuated by the predetermined level.

Decreasing the Low-Cut Filter Corner Frequency (3 dB down point)

1. Calculate a new capacitor value for the lower low-cut corner frequency. Use the following formula:

$$C \text{ in } \mu\text{F} = (85/\text{frequency}) - .33$$

Example for 200 Hz corner frequency
 $85/200 = .43$
 $.43 - .33 = .1 \mu\text{F}$

For a 200 Hz corner frequency, use a 0.1 μF capacitor.

Note: The capacitor must be a ceramic or film type, non-polarized, with a 16 V or higher rating.

2. For Input 1, locate X811 and X812. Solder the new capacitor between these points.
3. For Input 2, locate X813 and X814. Solder the new capacitor between these points. Also locate X815 and X816 on the bottom board, just behind the input gain controls. Solder another new capacitor between these points.
4. For Input 3, locate X809 and X810 on the bottom board, just behind the input gain controls. Solder the new capacitor between these points.
5. To raise the corner frequency higher than the factory preset of 260 Hz, contact the Shure Technical Application Group at (847) 866-2525.

Slowing Down Output Level Meters to Approximate “True VU” Ballistics

1. Locate empty pads C302 and C303 on the top PC board, behind the power switch.
2. Solder a 150 μF x 6.3 V electrolytic capacitor in C302. The + lead must face the meters.
3. Solder a 150 μF x 6.3 V electrolytic capacitor in C303. The + lead must face the meters.
4. To slow the meter response even more, further increase the μF value of C302 and C303.

Changing Battery Indicators to Monitor Internal or External Power

The following modifications allow only the internal batteries or the external power supply to be monitored at the VU meter.

| | | |
|----------------------|--------------------------------|--|
| Modification: | To monitor external power only | To monitor internal battery power only |
| Procedure: | Remove R492 | Remove R490 |

The following modifications allow the Red/Green Power LED to indicate low voltage status for only the internal battery or the external power supply.

| | | |
|----------------------|-------------------------------------|---|
| Modification: | To indicate low external power only | To indicate low internal battery power only |
| Procedure: | Remove R493 | Remove R491 |

Other Available Modifications

- Changing VU Meter Scale for Battery Voltage Indication
- Converting FP32 to FP32A or FP33 Mix Bus
- Increasing Output Level of Slate Mic
- Power LED Red Flashing Point
- Reduction of Headphone Circuit Output Impedance
- Single Output Level Control
- XLR Connector Change from Female to Male

For further information about these modifications, call the Shure Technical Application Group at (847) 866–2525.

SPECIFICATIONS

Measurement conditions, unless otherwise specified: Operating Voltage: 18 Vdc

Full gain

1 kHz input signal.

Output terminations: Line 600 Ω; Mic 150 Ω;

Tape Out 50 kΩ, Headphone 200 Ω.

Frequency Response

20 to 20,000 Hz ±2.0 dB (channel controls centered).

Voltage Gain

| Input | Line | Mic | Headphone | Tape |
|-------------------|-------|--------|-----------|-------|
| Low-Z Mic (150 Ω) | 78 dB | 28 dB | 89 dB | 66 dB |
| Line | 28 dB | -22 dB | 39 dB | 16 dB |
| Monitor | — | — | 11 dB | — |

Inputs

| Input | IMPEDANCE | | Input Clip Level |
|---------|-----------------------|-------------------|------------------|
| | Designed for Use with | Actual (Internal) | |
| Mic | 19 to 600 Ω | 1 kΩ | -10 dBV |
| Line | ≤10 kΩ | 50 kΩ | +36 dBV |
| Monitor | ≤ 1 kΩ | 10 kΩ | +21 dBV |

Outputs

| Input | IMPEDANCE | | Output Clip Level |
|------------|-----------------------|-------------------|-------------------|
| | Designed for Use with | Actual (Internal) | |
| Mic | Low-Z inputs | 1 Ω | -31 dBV |
| Line | 600 Ω | 150 Ω | +18 dBm |
| Tape | >10 kΩ | 2.2 kΩ | +3 dBV |
| Headphones | 8 to 200 Ω | 300 Ω | +11 dBV |

Total Harmonic Distortion

0.25% THD at +4 dBm output, 50 to 20,000 Hz.

Equivalent Input Noise

-127 dBV with 150 Ω source, 20 to 20,000 Hz.

Output Noise

Master level fully CCW: ≤ -100 dBV, 20 to 20,000 Hz.

Master level fully CW: ≤ -80 dBV, 20 to 20,000 Hz.

Common Mode Rejection Ratio

65 dB at 100 Hz, -20 dBV input.

Polarity

| | |
|-----------------------------|---------------|
| Mic/Line In to Mic/Line Out | Non-Inverting |
| Mic/Line In to Headphones | Non-Inverting |
| Mic/Line In to Tape Out | Non-Inverting |
| Mic/Line to Mix Bus | Inverting |
| Monitor In to Headphones | Non-Inverting |

Overload and Shorting

Shorted outputs, even for prolonged periods, cause no damage. Microphone inputs of up to 3 Vrms cause no damage. The Line and monitor inputs can withstand signals of up to 30 Vrms.

Input Channel Bi-Color LEDs

Green: Signal presence; visual indication of mix level.
Red: 6 dB below clipping level.

Output Peak/Limiter Bi-Color LEDs

Green: Output being limited by 1 dB or more.
Red: Output peak threshold reached; factory set at +17 dBm; user adjustable from 0 to 17 dBm.

Output Clipping Level

≥ +18 dBm at line output into 600 Ω.

Low-Cut Filters

6 dB down at 150 Hz; 6 dB/octave slope.

Pan Attenuation Level

45 dB.

Tone Oscillator

1 kHz ±10%.

Slate Tone Oscillator

400 Hz ±10%.

Limiter

Threshold: Adjustable; 0 dBm to +15 dBm.
Attack Time: 1 ms.
Release Time Constant: Selectable; 100 ms or 1 s.
Indicator: Green when limiting by 1 dB or more.

Microphone Power

12 V Phantom: 12 V through matched 680 Ω.
48 V Phantom : 48 V through matched 6.8 kΩ.
12 V T (A-B):12 V through matched 180 Ω.

Mixer Power

Internal: Two 9 V alkaline batteries.
External: 12-30 Vdc to dc In jack; non-polarized.
Current Drain: Approximately 41 mA (idle) at 18 V.
Battery Life: 8 hours minimum, typical.

Temperature Range

Operating: 0° to 60° C (32° to 140° F).
Storage: -40° to 85° C (-40° to 185° F).

Overall Dimensions (H x W x D)

58 mm x 184 mm x 161 mm (7-1/4 x 6-3/8 x 2-1/4 in.).

Net Weight (without batteries)

1.6 kg (3.5 lbs).

FURNISHED ACCESSORIES

Carrying Case 26A19

To wrap the carrying case around the FP33 mixer, refer to the assembly instructions supplied.

Shoulder Strap 95A8508

Connect the strap's swivel hooks to the metal ears located on the FP33 side panels.

Mix Bus Cable 90A4313

A three-conductor, shielded cable 205 mm (8 in.) long with a female 3-pin "Tini Q-G" connector at each end.

Rubber Feet 66A8010

If desired, these adhering feet may be placed on the bottom or the rear of the FP33 mixer.

Spare Fuse 187AJ06A

STATEMENT OF CONFORMITY

Conforms to European Union directives, eligible to bear CE marking; meets European Union EMC Requirements.

- **Emissions** (EN 50 081-1, 1992): CISPR 22.
- **Immunity** (EN 50 082-1, 1992).

Note: Under extreme conditions of electrostatic discharge to the VU Meter Lamp Switch, the VU meter may illuminate. This is normal and causes no harm.

INFORMATION TO USER

Changes or modifications not expressly approved by Shure, Inc., could void your authority to operate this equipment.

This equipment has been tested and found to comply with the limits for a Class B digital device pursuant to Part 15 of the FCC Rules and as set out in the Radio Interference Regulations of the Canadian Department of Commu-

nications. These limits are designed to provide reasonable protection against harmful interference in a residential installation. This equipment generates, uses, and can radiate radio frequency energy and, if not installed and used in accordance with the instructions, may cause harmful interference to radio communications. However, there is no guarantee that interference will not occur in a particular installation. If this equipment does cause harmful interference to radio or television reception (which can be determined by turning the equipment off and on), the user is encouraged to try to correct the interference by one or more of the following measures:

1. Reorient or relocate the receiving antenna.
2. Increase the separation between the equipment and the receiver.
3. Connect the equipment into an outlet on a circuit different from that to which the receiver is connected.
4. Consult your dealer or an experienced radio/TV technician.



SHURE Incorporated Web Address: <http://www.shure.com>
222 Hartrey Avenue, Evanston, IL 60202-3696, U.S.A.
Phone: 847-866-2200 Fax: 847-866-2279
In Europe, Phone: 49-7131-72140 Fax: 49-7131-721414
In Asia, Phone: 852-2893-4290 Fax: 852-2893-4055
Elsewhere, Phone: 847-866-2200 Fax: 847-866-2585